

/// Plug-in railway relay

Rugged plug-in relays for extreme reliability, within long endurance applications and harsh environments

N.S1-P-24-12.0.8

Instantaneous relay, signalling, post



Description

The N.S1-P-24-12.0.8 24 VDC instantaneous electro-mechanical vital relay is a track side safety relay for the signalling railway market.

It is a dual module plug-in relay with positive mechanical keying, equipped with 12 normally open contacts and 8 normally closed contacts.

Application

The N.S1-P-24-12.0.8 is designed for applications such as signaling light control, automatic gate control, point mechanism control, control room.

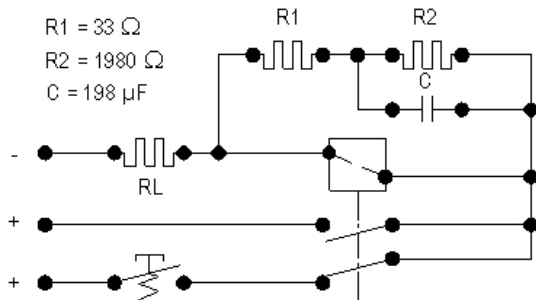





Wiring A according NF F 70-031 (Operation @ pick-up)
 Minimum command time is 5 s

Features

- Instantaneous electro-mechanical vital relay
- Weld resistant contacts
- Weld no transfer contacts
- Gravity drop out
- Solid gold and bifurcated contacts
- -25 °C...+70 °C operating temperature

Marking

  		
Désignation : N.S1-P-24-12.0.8		
N° de fabricant : 001		
Symbole : 7.954.0231		
		ISO MM
U nominal (V)	24	Date Recept.
R à 15°C (Ω)	250	01.93
I chute (mA)	26.5	Code
I attr. (mA)	46.1	K 74
I comp. (mA)	46.1	

 	
N.S1-P-24-12.0.8	
N° 001	

Contact & marking

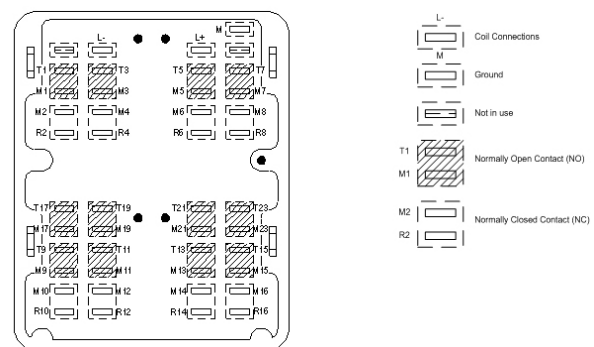

Timing diagram

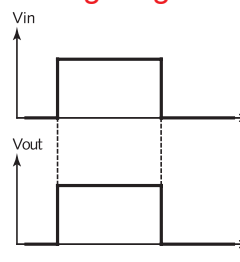

Railway compliancy

NF F70-030 August 2004
 NF F70-020 September 1991
 NF F70-031 - Type approval testing procedure
 NF F70-032 - Series acceptance test procedure

Technical specifications

Instantaneous relay N.S1-P-24-12.0.8

Function

Function	Signalling, track side
Housing type (# modules)	2
Contact arrangement: Normally Open (N/O)	12
Change Over (C/O)	0
Normally Closed (N/C)	8
Number of command elements (coils)	1

Contact characteristics

Travel and minimum contact gap: Minimum travel between the opening of the last making contact and the closing of the first breaking contact (neutral)	0.7 mm
Minimum fixed contact over travel	0.5 mm
Normally open contacts minimum gap when mobile armature is in rest position	1.2 mm
Normally closed contacts minimum gap when mobile armature is picked up	1.2 mm
Alignment	All contacts of the same type must close simultaneously, with a tolerance of 0.3 mm between making of the first and the last contact
Contact pressure	Normally closed: ≥ 0.2 N Normally open: ≥ 0.2 N
Maximum contact bounce time	20 ms

Operating time (ms)

Total pick-up time	$5 \text{ ms} < T_a < 100 \text{ ms}$
Normally open contacts opening time on drop-out	$5 \text{ ms} < T_c < 30 \text{ ms}$
Pick-up transfer time	$1 \text{ ms} < t_a < 40 \text{ ms}$
Drop-out transfer time	$1 \text{ ms} < t_c < 20 \text{ ms}$

General characteristics

Nominal voltage	24 VDC (-6...+20 %)
Coil resistance at 15 °C	250 ohm ± 5 %
Maximum resistance which can be connected in series with the coil	10 ohm
Coil RMS voltage at 50 Hz frequency, which can be applied without generating the closing of an of the N/O contacts	150 V
Minimal drop-out torque	0.15 Nm
Dimensions	152.5 x 100 x 123 mm
Weight	< 1.50 kg

Electrical characteristics

Pick up current	$I_t < 64 \text{ mA}$
Drop out current	$20 \text{ mA} < I_c < 36 \text{ mA}$
Sensitivty (I_c/I_t ratio)	$s > 0.30$

Instantaneous relay N.S1-P-24-12.0.8

Environmental characteristics

Vibration	0.25 g in X, Y, Z axis
Shock	n/a (track side relay)
Operating temperature	-25 °C...+70 °C
Humidity	95 % @ 20 °C
Salt mist	ISO 9227 for 96 h
Protection	IP 40
Fire & Smoke	Polycarbonate (cover) / polyphenylene (base)

Dimensions

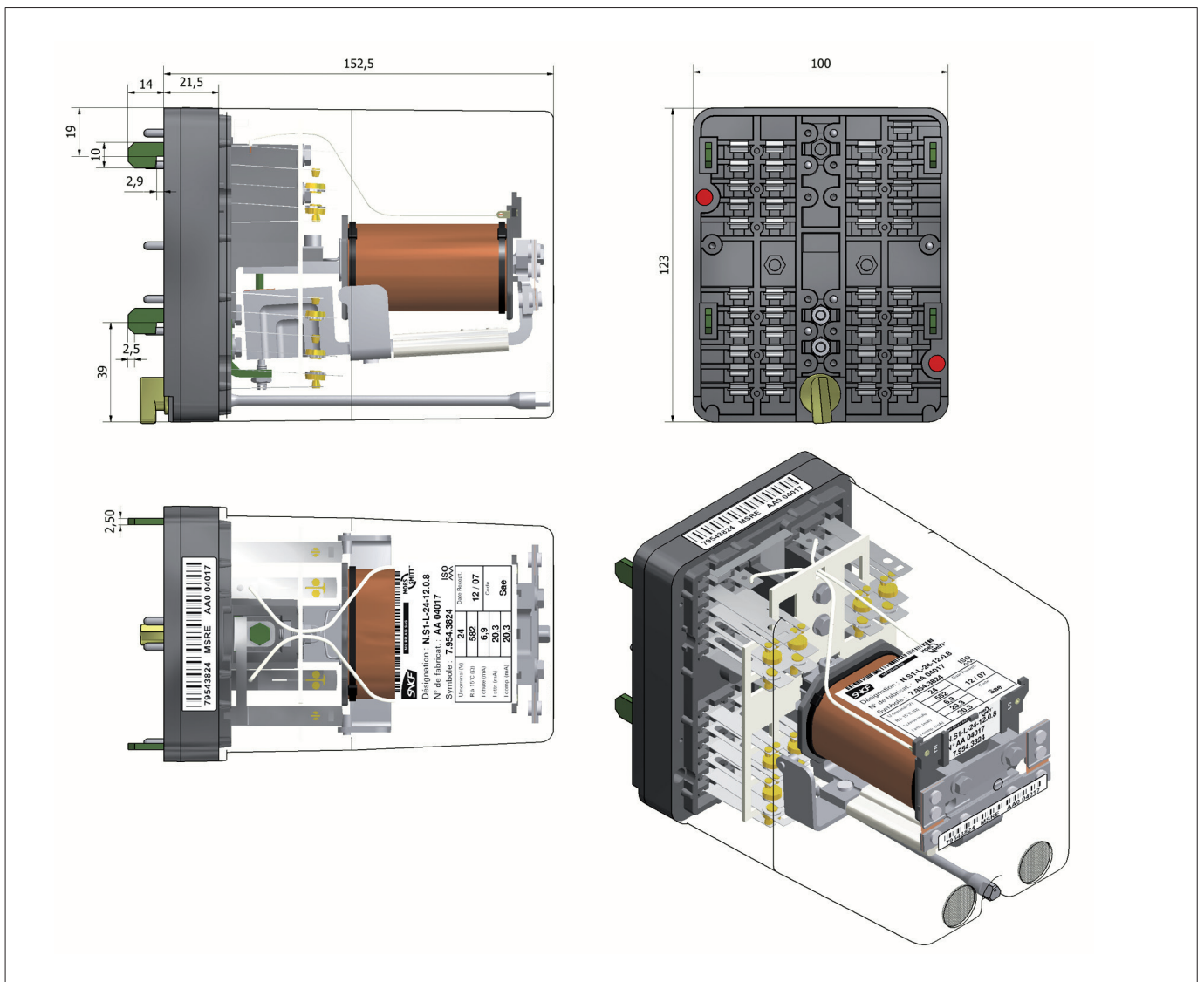

Instantaneous relay N.S1-P-24-12.0.8

Accessories

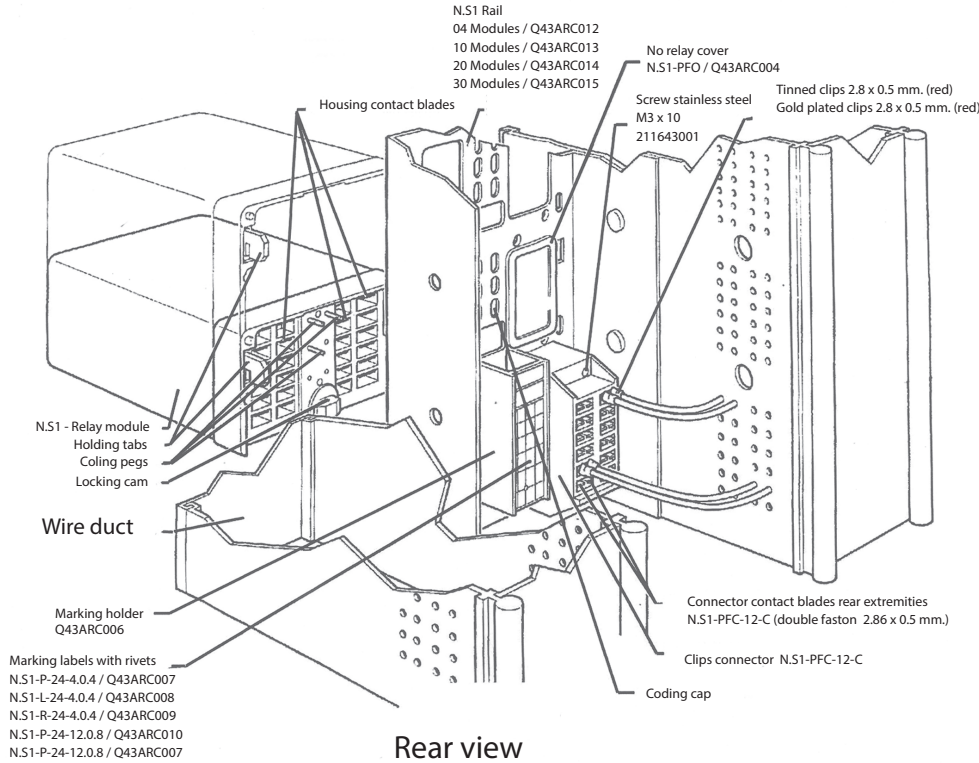

Rail mounting accessories				
N.S1 rail	4 modules		Q43ARC012	quantity varies
	10 modules		Q43ARC013	quantity varies
	20 modules		Q43ARC014	quantity varies
	30 modules		Q43ARC015	quantity varies
Marking labels with rivets		Q43ARC010	1	
No relay snap-on cover	N.S1-PFO	7.954.0381	Q43ARC004	optional
No relay empty connector with screws and contacts coding	N.S1-PFCO	7.954.4543	Q43ARC005	optional
N.S1 Coding cap		7.966.0496	Q43ARC003	16 per module
Marking holder		7.966.0494	Q43ARC006	2
Screw stainless steel M3x10			211643011	8 per 2 modules
Screw zinc brichomated M3x10			60301106	8 per 2 modules
N.S1 Locking wrench			Q43ARC001	quantity varies
Tinned clips 2.8 x 0.5 mm (red)	AMP 140 822-1 or MTR 51031-2	7.847.4609	OEA408221	quantity varies
Gold plated clips 2.8 x 0.5 mm (red)	AMP 140 822-3 or MTR 51027 (gold)	7.847.4593	OEA408222	quantity varies
Clip connector	N.S1-PFC.12-C		Q43ARC002	4 per module
Wall mounting Front mount connector	N.S1-PFC-12.AV-24	7.954.3895	Q43ARC017	2 per module

Instantaneous relay N.S1-P-24-12.0.8

Instructions for use

Installation

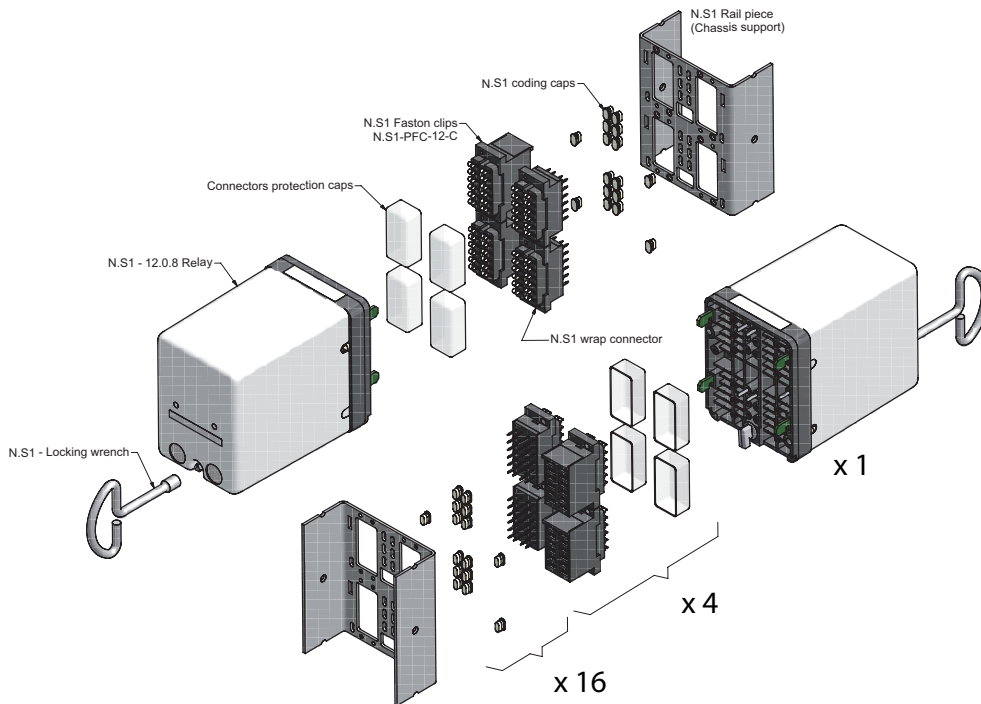

- N.S1 relay are modular with automatic connector and cam locking.
- Through wall mounting: 4x N.S1-PFC12-C rear connection with faston clip, or 4x N.S1-PFC12-W rear wrap connection.
- Wall mounting: 2x N.S1-PFC-AV-24 front connection with screw terminals
- Check the relay pin code before installation. The relay must be installed in its natural position (i.e. horizontal with mobile part above). Lock the relay in position.

Operation

Before operating, check the integrity of the relay.

Maintenance

Correct operation of relay can easily be checked as transparent cover gives good visibility on the contacts. Relay service life, specified by the end user, depends of the circuit the relay is in use. For regular inspection process of our signalling relays please refer to our instruction document reference IQ2000-030.

RMA procedure see www.morssmitt.com

Instantaneous relay
N.S1-P-24-12.0.8

Ordering scheme

N.S1	-	P-24	-	12	.	0	.	8
------	---	------	---	----	---	---	---	---

 **Over 10 million Mors Smitt relays in use in rail transport applications worldwide!**

Mors Smitt Asia Ltd.
26/F., Casey Aberdeen House
38 Heung Yip Road, Wong Chuk Hang
Hong Kong
Tel: +852 2343 555
sales.msa@wabtec.com

Mors Smitt France SAS
2 Rue de la Mandinière
72300 Sablé-sur-Sarthe, France
Tel: +33 (0) 243 92 82 00
sales.msf@wabtec.com

Mors Smitt UK
Graycar Business Park,
Burton on Trent, DE13 8EN, UK
Tel: +44 (0)1283 357 263
sales.msuk@wabtec.com

Wabtec Netherlands B.V.
Darwinstraat 10,
6718 XR Ede, Netherlands
Tel: +31 (0)88 600 4500
sales.msbv@wabtec.com

Mors Smitt Technologies Ltd.
1010 Johnson Drive,
Buffalo Grove, IL 60089-6918, USA
Tel: +1 847 777 6497
salesmst@wabtec.com

RMS Mors Smitt
19 Southern Court,
Keysborough, VIC 3173, Australia
Tel: +61 (0)3 8544 1200
sales.rms@wabtec.com

(c) Copyright 2022

All rights reserved. Nothing from this edition may be multiplied, or made public in any form or manner, either electronically, mechanically, by photocopying, recording, or in any manner, without prior written consent from Mors Smitt. This also applies to accompanying drawings and diagrams. Due to a policy of continuous development Mors Smitt reserves the right to alter the equipment specification and description outlined in this datasheet without prior notice and no part of this publication shall be deemed to be part of any contract for the equipment unless specifically referred to as an inclusion within such contract. Mors Smitt does not warrant that any of the information contained herein is complete, accurate, free from potential errors, or fit for any particular purpose. Mors Smitt does not accept any responsibility arising from any party's use of the information in this document.