

Arc Flash Protection 1S20

High speed arc fault protection for metal clad air Insulated switchgear utilizing optical sensors.

- > Compact, economic design
- > Simple panel mounting for retrofit applications
- > Two or three arc sensor inputs
- > Made in Australia





Figure 1: 1S20 surface mount version front panel

Features

- > Compact, economic design
- > Simple panel mounting for retrofit applications
- > Two or three arc sensor inputs
- > Two high speed tripping duty arc sense output contacts
- > Push button reset
- > Continuous arc sensor supervision
- > Integrated self-supervision
- > Fail alarm contact
- > 24, 32, 48, 110, 125, 220, 240, and 250 V AC/DC auxiliary

Application

Utilised in either new installations or as a simple retrofit in existing installations, the 1S20 provides high speed detection and signalling of arc flash hazards for application in air insulated metalclad switchgear.

Arc fault protection schemes may be implemented on an arc only basis, or alternatively a current check may be employed where additional security is warranted.

A current checked scheme may be implemented by making use of available protection relay logic and a fast acting instantaneous overcurrent element.

Some typical application examples are shown on the Application page together with an example schematic.

For further application information refer to the 1S20 User Guide.

The 1S20 is packaged in the ZA12 case that may be flush panel, surface or rail mounted.

A plug in terminal block is provided to allow panel pre-wiring.

Arc Flash Protection

Arc fault protection is a relatively new technique employed for the clearance of arcing faults on low voltage panels, MCC's, BUS bars and within metal clad switchgear and associated cable boxes.

Conventional current based protection techniques are at times challenged by the nature of arcing faults, and can result in slow protection clearance times. Slow protection clearance times increase the risk to nearby personnel and increase the degree of damage to plant and equipment.

By employing an optical detection technique, Arc Fault Protection results in fast clearance of arcing faults.

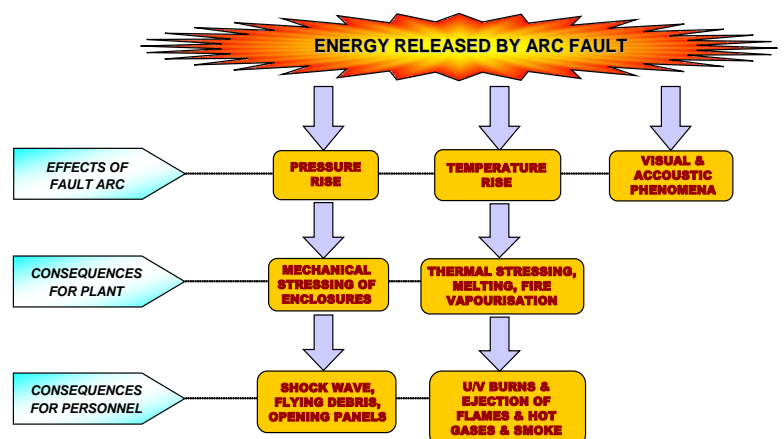

Arc Sensors

The 1S20 is designed to monitor remote optical sensors that respond to the flash of light emitted during the incidence of an arcing fault. Onset of the light flash & detection by the sensors occurs in a few ms.

1S30 Point Sensor

The 1S30 is an electrically wired point sensor suitable for application in discrete compartments in metal clad switchgear and cable ducts. When an arc is detected, the resistance presented by the 1S30 drops to a level where the current flow increases to approximately 20mA. This increased current flow is instantaneously detected by the 1S20 & its trip output contacts closed. Refer to the 1S30 Technical Bulletin for further details.



Figure 2: 1S30 Point Sensors

Low Current Arcing Faults

Arcing faults can occur at low current levels and it is possible for the over-current starter element to be set above this level. To avoid this problem & obtain very fast clearance (<10ms), of an arc fault, the 1S20 arc fault trip contact may be wired directly to the breaker operate coil. It should be noted that this method may lead to reduced system security.

Independent Trip Output Contacts

The 1S20 may be set using configuration switch 3 for both trip output contacts to pick up when an arc is detected by any sensor input. Alternatively arc sensor 1 can be linked to trip contact 1 & arc sensor 2 (& 3 if fitted), to trip contact 2. This function may be applied where an arc fault detected in the cable box is directed to trip the feeder circuit breaker while an arc fault in the BUS chamber is to be directed to trip the BUS.

Arc Fault Tripping Using Current Check

Fast operation of a tripping scheme usually results in reduced system security. The arc detection method can however, combine the 1S20 optical detection technique with a traditional overcurrent method to maximize system security particularly for BUS bar protection schemes. Both conditions must coexist for the trip condition to be met as depicted in figure 3.

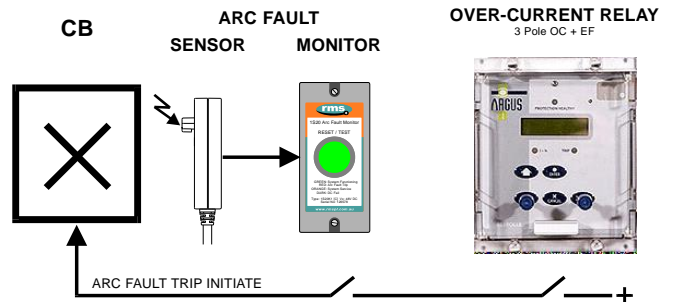

Figure 3:

Key components required to implement an Arc Fault Protection scheme with an overcurrent check stage to enhance system security.

The application examples in figures 4 to 8 utilize this concept for enhanced system security in that both the 1S20 AND the OC 50 starter contact must be picked up for a CB trip signal to be initiated. As the arc fault trip contact picks up considerably faster than the overcurrent relay starter element, the CB trip time will be dictated by the overcurrent relay performance.

Arc Sensor Continuously Picked Up

High ambient light levels may cause a 1S30 to be continuously picked up. This condition could occur for example if the CB cable box cover was left open in very high ambient light level conditions.

To avoid possible mal operation due to this condition, the 1S20 is designed to automatically disable the arc fault tripping function if any sensor input is picked up for >10s. The 1S20 alarm contact will be set & the front LED flash alternate orange & red until the ambient light level problem is corrected. The 1S20 will then perform an arc sensor test function & automatically reset.

Arc Detection Reset Time

(Effect of multiple arc trips)

A delay of 2s is required to reset the 1S20 after an initial arc sensor trip. Subsequent arc detection will cause the trip output contacts to re-operate.

Switchgear ARC Flash Protection

Risk of arc fault damage exists at the CB cable termination and in the CB chamber itself. The CB cable termination is particularly at risk to ingress of moisture and rodent damage.

One, two or three arc sensors may be connected to the 1S20 Arc Fault Monitors as depicted in the single line application diagrams at right.

Figures 4 and 5 show the trip signals being used to trip the feeder circuit breaker in the event of an arc fault occurring at any sensor provided the overcurrent relay starter contact is picked up. In these applications the overcurrent check stage is optional as the consequence of a single feeder outage is less than the loss of an entire BUS.

Figure 7 shows an application where a single 1S20 is applied for the protection of the Cable box, CT chamber and CB chamber using three sensors. In this configuration one arc trip output is used to trip the feeder circuit breaker in the event of an arc fault in the cable box / CT chamber. The second trip output is set for independent operation to trip the BUS breaker (BUS overcurrent check not shown), in the event of an arc fault in the CB chamber.

Existing Switchgear Applications

The existing overcurrent relay protecting the feeder will normally provide an independent output contact associated with the start current setting of the relay. That is an output contact that will close when a phase or earth fault current is detected above the threshold which starts the internal relay timers. This starter element should be set for instantaneous operation so that it will pick up in the order of 15ms.

An Arc Fault Monitor relay 1S20 is installed on the switchgear panel adjacent to the protection relay. The 1S20 is specifically designed for simple retrofit to existing panels or DIN rail mounted within the instrument chamber.

1S30 optical arc sensors are fitted in the cable termination box and CT chamber as depicted in figure 5.

The overcurrent relay starter contact may optionally be wired in series with the arc fault detection trip output contact as depicted in figure 6. The resulting "AND" function trip output is wired to trip the breaker in ~15ms in the event that an arc fault is detected while the overcurrent start element is picked up.

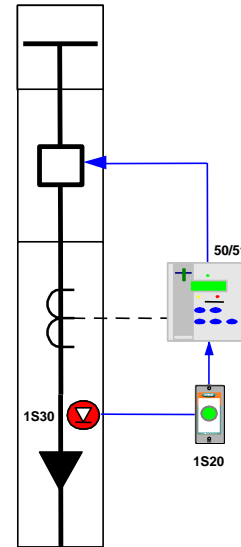

Figure 4:
Single point sensor - Cable box

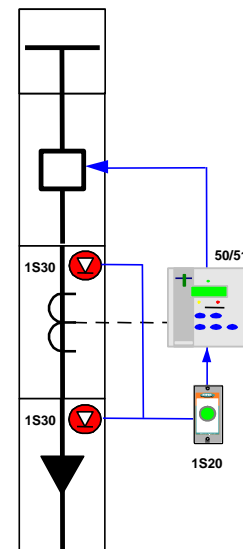

Figure 5:
Two point sensors - Cable box and CT chamber

New Switchgear Applications

For new switchgear installations a modern numeric feeder protection relay is likely to be employed which will have numerous programming and configuration options.

The basic concept is the same as for the existing switchgear application described above except that the additional features and flexibility of modern feeder protection relay allows improved system integration.

This may be achieved by using the second arc trip output contact to interface to a programmable status input on the feeder protection relay. Depending on the model of protection relay being used this input may be programmed to provide an alarm message on the HMI, time stamped event record available via its communications link.

Where this level of system integration is employed the 1S20 does not need to be mounted on the front panel as the alarm indications are available on the feeder relay. Remote reset of the 1S20 LED is achieved by momentary interruption of the power supply using a SCADA controlled series contact. The DIN rail mounting option is a convenient alternative in this situation.

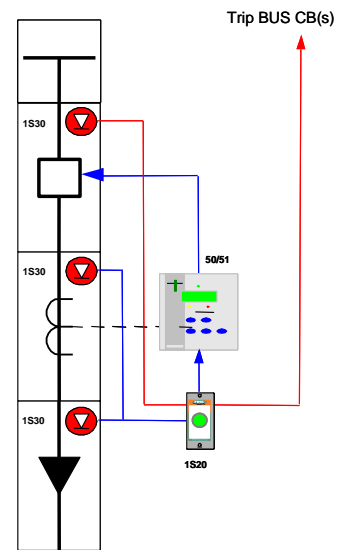

Figure 6:
Two point sensors in zone 1 - Cable box and CT chamber
One point sensor in zone 2 for CB chamber

Combined Bus Bar & Switchgear Arc Protection

Figure 7 shows an application where a single 1S20 is applied for the protection of the Cable box & CT chamber plus the CB chamber & BUS chamber using three sensors.

In this configuration one arc trip output is used to trip the feeder circuit breaker in the event of an arc fault in the cable box / CT chamber. The second trip output is set for independent operation to trip the BUS breaker (BUS overcurrent check stage not shown), in the event of an arc fault in the CB chamber or BUS chamber.

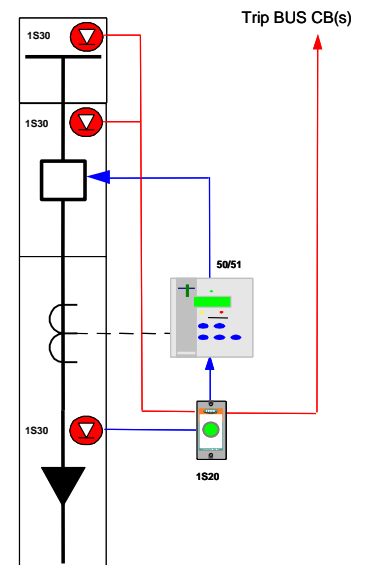

Figure 7:
One arc sensor - Cable box / CT chamber Independent trip to CB
Two arc sensors - CB chamber & BUS chamber Independent trip to BUS breaker
(BUS overcurrent check stage not shown)

Bus Bar Arc Protection

Figure 8 depicts how the 1S20 may also be applied for the protection of bus bars. The number of sensors in the bus chamber is dictated by the switchgear design and the length of switchboard.

In most indoor metal clad switchgear the bus bar chamber is a continuous chamber between panels only broken into segregated sections at a bus section breaker & as such the strategic placement of one or two arc sensors in each bus bar chamber run is normally adequate.

Some indoor metal clad switchgear may segregate the bus chamber of each panel from the next via insulated bus chamber side barriers per panel, if this is the case then each bus chamber per panel would need to be monitored by at least one arc sensor.

In large enclosures the arc sensors should be placed at approximately 5m intervals.

1S30 Shielded Cables

Shielded cables are recommended when the length of the 1S30 cable connections exceed 6m.

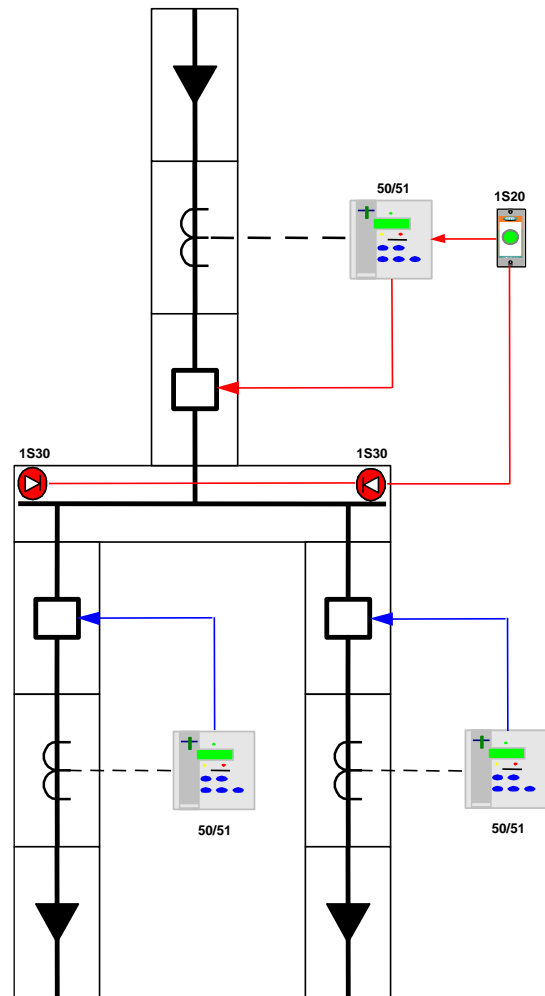

Figure: 8: Bus bar arc protection single line schematic

Operation Indicator

A single tri colour LED is integrated into the front panel reset push button to provide the following status indications:

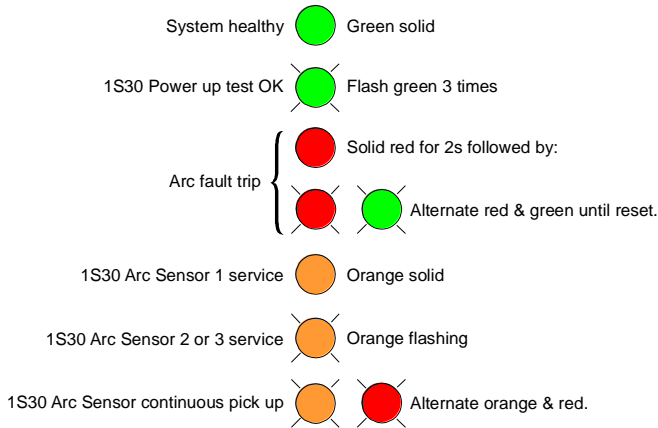

Figure 9: Front panel LED indication





Configuration Switch Settings

The internal wiring label identifies the position of the following switch functions:

- Switch 1: Arc sensor 2
 ON - Arc Sensor 2 fitted
 OFF - Arc Sensor 2 not fitted
- Switch 2: Arc fault trip indication LED reset
 ON - Latching until manually reset
 OFF - Automatic self-reset (Extinguish) after 4 hours Will also reset contacts set for latching function
- Switch 3: Independent arc trip output contacts
 ON - Arc Sensor 1 activates trip output contact 1 & Arc sensor 2 or 3 activates trip output contact 2
 OFF - Arc Sensor 1, 2 or 3 activate both trip outputs
- Switch 4: Arc fault trip output contact reset
 ON - Latching – Reset with trip LED
 OFF - Self-reset after 2s
- Switch 5: Arc sensor 3
 ON - Arc Sensor 3 fitted
 OFF - Arc Sensor 3 not fitted

Function Configuration

The configuration switches are accessible to the user by first unplugging the electronic module from the terminal base as shown in figures 10 and 11.

- | | | | |
|---------------------------|----|---|-----|
| 1: ARC SENSOR 2 | ON |  | OFF |
| 2: LATCHING TRIP LED | ON |  | OFF |
| 3: INDEPENDENT ARC TRIP | ON |  | OFF |
| 4: LATCHING TRIP CONTACTS | ON |  | OFF |
| 5: ARC SENSOR 3 | ON |  | OFF |

Note: Switch 5 is not fitted on 2 sensor variants

Figure 10: Front panel mode selector switch

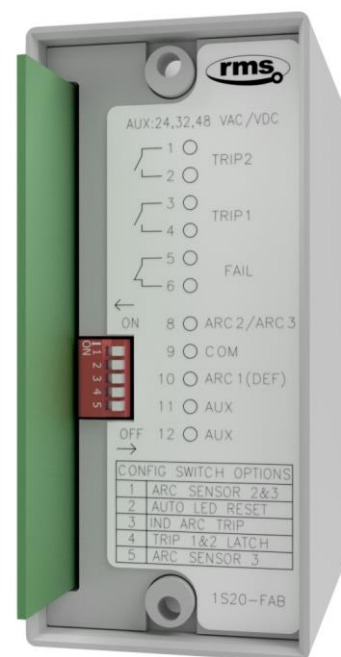

Figure 11: 1S20 rear view showing configuration switches

WARNING: Removal of the 1S20 from the base may expose live terminals

Arc Sensor Circuit Supervision

The 1S30 Arc Sensor is the heart of the system & supervision of circuit continuity is critical for correct operation. To monitor the integrity of the wiring between the 1S30 arc sensor & 1S20 Arc Monitor, a continuous 2mA supervision current flows between the units. The 1S20 alarm contact will drop out after a 1s time delay if it fails to detect this current.

Where a fault is detected on the Arc Sensor 1 circuit the front panel LED will give a solid orange indication.

Where a fault is detected on Arc Sensor 2 or 3 circuits the front panel LED will give a flashing orange indication.

Where a fault is detected on Arc Sensor 1 & 2 or 1& 3 circuits the front panel LED will give a solid orange indication.

Auxiliary Supply

Low Range Version	Order Code F
Nominal dc Voltage Supply	24 / 32 / 48
Standards Compliant Range (Shown on relay rating plate)	19-85V dc 19-65V ac
Absolute Range	18-100V dc 15-75V ac
Mid-Range Version	Order Code G
Nominal dc Voltage Supplies	110 / 125
Standards Compliant Range (Shown on relay rating plate)	45-165V dc 38-150V ac
Absolute Range	36-200V dc 30-175V ac
High Range Version	Order Code H
Nominal dc Voltage Supplies	220 / 240 / 250
Standards Compliant Range (Shown on relay rating plate)	125-250V dc 94-240V ac
Absolute Range	100-300V dc 75-275V ac
Allowable breaks/dips in supply (Collapse to zero)	As per IEC60255-26 *7.2.11
Burden - Quiescent	8W at 110V dc
Burden - Maximum	15W at 110V dc

Output Contacts

Operating Voltage	Voltage free
Operating Mode	Self-reset
Trip Contact Operate Time	<10ms (Flash to contact closure)
Reset Time	2s (Self reset setting)
Making Capacity	
Carry Continuously	5A ac or dc
Make and Carry L/R ≤ 40ms and ≤ 300V	20A ac or dc for 0.5s 30A ac or dc for 0.2s
Breaking Capacity	L/R ≤ 40ms and ≤ 300V
AC Resistive	1,250VA
AC Inductive	250VA at p.f. ≤ 0.4
DC Resistive	75W
DC Inductive	30W at L/R ≤ 40ms 50W at L/R ≤ 10ms
Minimum Load	100mA ≥12V

Operating Time

Arc fault trip contacts guaranteed to pick up in less than 10ms including bounce. Typical operate time is 7ms.

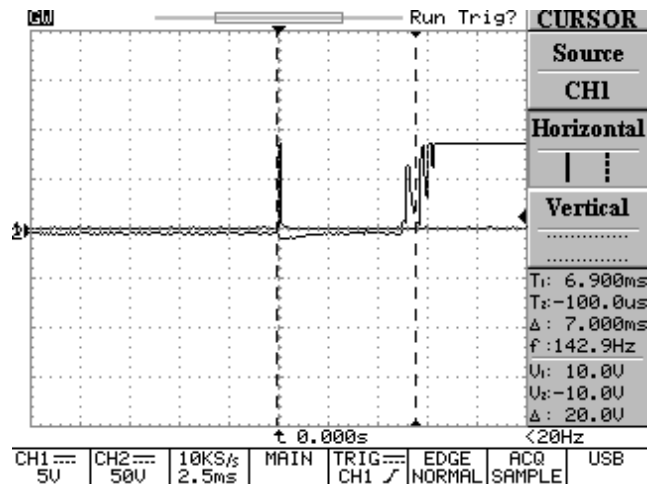

CRO trace showing nominal operation time of the trip contacts at 7ms. First contact touch at 6.25ms and fully closed by 7.25ms. Operation in <10ms is considered acceptable as current check relay operate time is ~15ms.

Arc Fault Point Sensor Inputs

Number	2 or 3
Type	1S30 point sensors
Connection	Electrical termination
Zones	1 or 2
Supervision duration	Continuous

Minimum Arc Duration

The minimum arc “flash” duration required to guarantee operation of the output contacts is 2.2ms.

Trip Contact Reset Time

Once operated the trip output contacts reset as per the configuration switch 4 setting.

Manual Reset

Press front button or interrupt power supply to reset LED's.

Case

ZA12 flush or DIN rail mount type

12 M4 screw terminals

Plug in module to facilitate easy wiring & fast changeover

ELECTRICAL ENVIRONMENT

AC and DC Voltage Dips

Standard	IEC 60255-26, #7.2.11
Test Level	Test specification
Dip to 0% of residual voltage Acceptance criterion A	DC: 20 ms AC: 1 cycle 50/60 Hz
Dip to 40% of residual voltage Acceptance criterion C	DC: 200 ms AC: 10/12 cycles 50/60 Hz
Dip to 70% of residual voltage Acceptance criterion C	DC: 500 ms AC: 25/30 cycles 50/60 Hz

AC and DC Voltage Interruptions

Standard	IEC 60255-26, #7.2.11 Acceptance criterion C
Test Level	Test specification
Drop to 0% of residual voltage	DC: 5 s AC: 250/300 cycles 50/60 Hz

AC Component in DC (Ripple)

Standard	IEC 60255-26, #7.2.12 Acceptance criterion A
Test Level	Test specification
15% of rated DC value	100/120 Hz, Sinusoidal

Gradual Shut-down/Start-up (DC Power Supply)

Standard	IEC 60255-26, #7.2.13 Acceptance criterion C
Test Identification	Test specification
Shut-down ramp	60 s
Power off	5 min
Start-up ramp	60 s

Clearances and Creepage Distances

Standard	IEC 60255-26, #10.6.3
Test Identification	Test specification
Pollution degree	2
Overvoltage category	III
Rated insulation voltage	300 V rms or dc
Clearances and Creepage Compliance	CAD drawings assessment

Safety-related Electrical Tests

Standard	IEC 60255-27, #10.6.4
Test Identification	Test specification
Between Independent Circuits	5 kV 1.2/50 μ s 0.5 J 3 pulses of each polarity 2.0 kV ac rms for 1 minute
Any Terminal and Earth	5 kV 1.2/50 μ s 0.5 J 3 pulses of each polarity 2.0 kV ac rms for 1 minute
Across Normally Open Contacts	1 kV ac rms for 1 min

Electrical Environment and Flammability

Standard	IEC 60255-27, #10.6.5
Test Identification	Test specification
Single-fault condition	Assessment
Maximum temperature of accessible parts at ambient temperature +40°C	Metal parts: < 70°C Non-metallic parts: < 80°C
Flammability of insulating materials, components and fire enc	Assessment

Reverse Polarity and Slow Ramp Test

Standard	IEC 60255-27, #10.6.6
Test Identification	Test specification
Maximum voltage dc	V start-up + 20%
Minimum voltage dc	V shutdown - 20%
Ramp down/up gradient	1 V/min

ATMOSPHERIC ENVIRONMENT

Temperature

Standard	IEC 60068-2-1, IEC 60068-2-2	
Test Identification	Test specification	Auxiliary power Supply voltage
Operating Range	-10 to +55°C	Min and Max
Storage Range	-25 to +70°C	Non-energized
Test duration	16 h at top and bottom temperatures	

Damp Heat (Humidity)

Standard	IEC 680068-2-78	
Test Identification	Test specification	
Operating Range	40°C and 93% RH non condensing	
Test duration	16 h	

IP Rating

Standard	IEC 60529	
Test Identification	Test specification	
Installed	IP4x	

MECHANICAL ENVIRONMENT

Vibration - Sinusoidal

Standard	IEC 60255-21-1 Class 1	
Test Identification	Test specification	Variation
Vibration Response in each of 3 axes	0.035 mm/0.5 gn peak 1 sweep cycle 10-150 Hz	No Mal-Op
Vibration Endurance in each of 3 axes	1.0 gn peak 20 sweep cycles 10-150 Hz	Non-energized

Shock and Bump

Standard	IEC 60255-21-2 Class 1	
Test Identification	Test specification	Variation
Shock Response in each of 3 axes	5 gn, 11 ms, 3 pulses in each direction	No Mal-Op
Shock Withstand in each of 3 axes	15 gn, 11 ms, 3 pulses in each direction	Non-energized
Bump Test in each of 3 axes	10 gn, 16 ms, 1,000 bumps in each direction	Non-energized

Seismic

Standard	IEC 60255-21-3 Class 1	
Test Identification	Test specification	Variation
Seismic Response Horizontal, on each axis	3.5 mm/1.0 gn, 1 sweep cycle 1-35Hz	No Mal-Op
Seismic Response Vertical	1.5 mm/0.5 gn, 1 sweep cycle 1-35Hz	No Mal-Op

ELECTROMAGNETIC COMPATIBILITY (EMC)

IMMUNITY

Electrostatic Discharge (ESD)

Standard	IEC 60255-26, #7.2.3, Acceptance criterion B	
Port	Enclosure	
Test Identification	Test specification	Variation
Air Discharge	8 kV	No Mal-Op

Radiated Electromagnetic Field

Standard	IEC 60255-26, #7.2.4, Acceptance criterion A	
Port	Enclosure	
Test Identification	Test specification	Variation
Frequency sweep	10 V rms, 80 to 1000 MHz 1400 to 2700 MHz	No Mal-Op
Spot frequencies	10 V rms, 80, 160, 380, 450, 900, 1850 & 2150 MHz	No Mal-Op

Fast Transients (EFT)

Standard	IEC 60255-26, #7.2.5, Acceptance criterion B	
Port	Auxiliary power supply, Input and Output, Functional Earth	
Test level	Test specification	Variation
Zone A	4 kV peak, 5/50 ns, 5 kHz	No Mal-Op

Slow Damped Oscillatory Wave (HFD)

Standard	IEC 60255-26, #7.2.6, Acceptance criterion B	
Port	Auxiliary power supply, Input and Output	
Test Identification	Test specification	Variation
Common Mode	1 MHz 2.5 kV peak	No Mal-Op
Differential Mode	1 MHz 1.0 kV peak	No Mal-Op

Surge

Standard	IEC 60255-26, #7.2.7, Acceptance criterion B	
Port	Auxiliary power supply, Input and Output	
Test Identification	Test specification	Variation
Line-to-earth	4 kV peak	No Mal-Op
Line-to-line	2 kV peak	No Mal-Op

Conducted Disturbance Induced by RF Fields

Standard	IEC 60255-26, #7.2.8, Acceptance criterion A	
Port	Auxiliary power supply, Input and Output, Functional Earth	
Test Identification	Test specification	Variation
Frequency sweep	10 V rms, 0.15 to 80 MHz	No Mal-Op
Spot frequencies	10 V rms, 27 & 68 MHz	No Mal-Op

Power Frequency Magnetic Field

Standard	IEC 60255-26, #7.2.10	
Port	Enclosure only	
Test Identification	Test specification	
Continuous ≥ 60 s	30 A/m - Acceptance criterion A	
Short time 1 s to 3 s	300 A/m - Acceptance criterion B	

EMISSION

Emission Enclosure

Standard	IEC 60255-26, #5.1	
Test Identification	Frequency range	Limits, dB ($\mu\text{V}/\text{m}$)
Radiated emission <1 GHz	30 - 230 MHz	40, quasi peak at 10 m 50, quasi peak at 3 m
	230 - 1000 MHz	47, quasi peak at 10 m 57, quasi peak at 3 m
Radiated emission >1 GHz	1 - 3 GHz	56, average 76, peak at 3 m
	3 - 6 GHz	60, average 80, peak at 3 m

Emission Auxiliary Power Supply Port

Standard	IEC 60255-26, #5.2	
Test Identification	Frequency range	Limits, dB ($\mu\text{V}/\text{m}$)
Conducted emission	0.15 - 0.50 MHz	79, quasi peak 66, average
	0.5 - 30 MHz	73, quasi peak 60, average

1S20 Wiring Diagrams

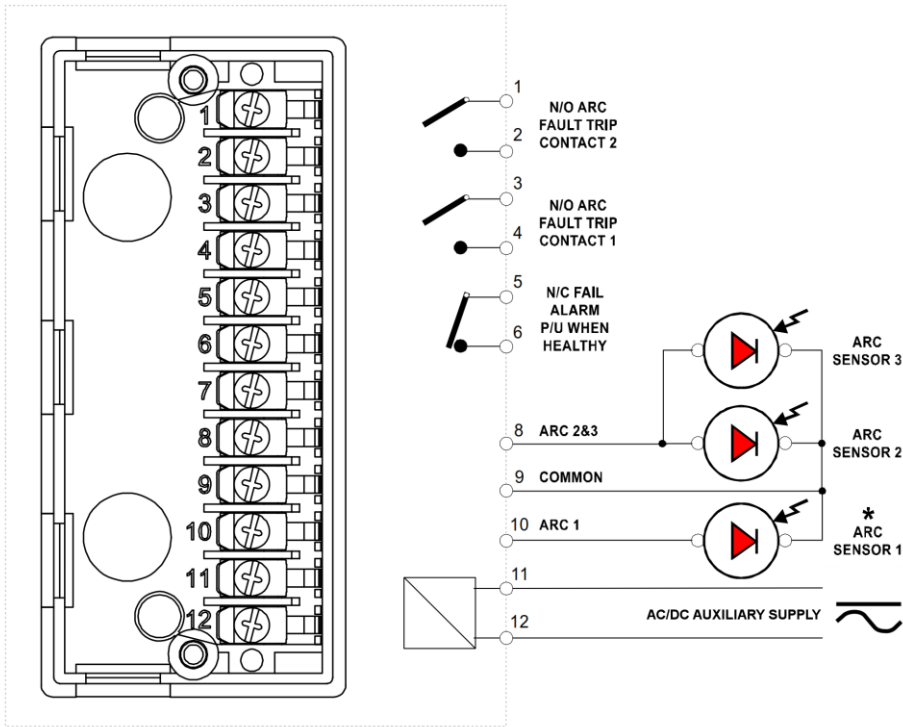

Layout viewed from the front when un-plugged from the main housing.

Note: * Always wire Arc Sensor 1. Arc Sensors 2 & 3 are optional

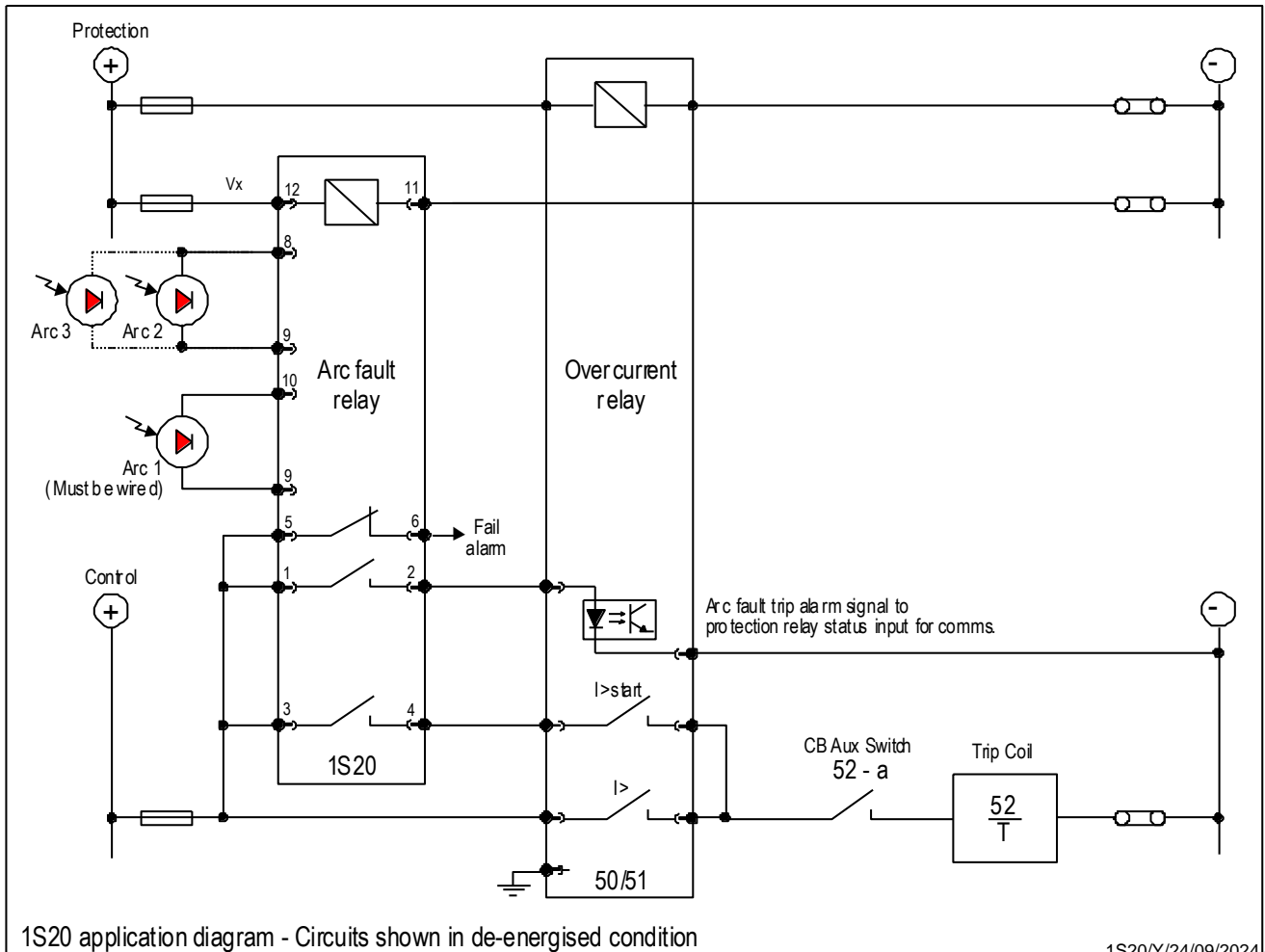

1S20 application diagram - Circuits shown in de-energised condition

Mounting Options

The 1S20 is available in two versions:

1. A surface mount version which has a separate reset button & LED indicator on the front panel. The advantage of this version is the lower cost & where front panel space is limited.
2. A panel mount version which has a combined reset button & LED indication. The advantage of this version is that it can be either panel or surface mounted.

Surface Mount Version

This version is suitable for location in the rear of a cubicle. It may be surface mounted as shown in figures 13, 14 and 18. It may also be DIN rail mounting when the optional 290407157 DIN Rail Mounting Kit is fitted. Refer figures 21 and 22.



Figure 13: 1S20 surface mount version front panel

Panel Mount Version

This version is suitable for mounting on the front panel of a cubicle or door. This is achieved using a 31mm diameter hole in the panel adjacent to the protection relay as depicted in figures 15, 16 and 17.

This version may also be surface mounted by reversing the terminal block retaining screws. It may also be DIN rail mounting when the optional 290407157 DIN Rail Mounting Kit is fitted. Refer figures 19 and 22.



Figure 15: 1S20 through hole panel mount version

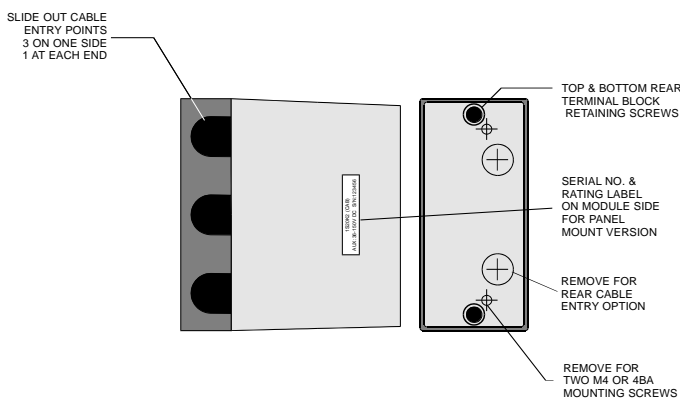

Figure 14: Surface mount version side view

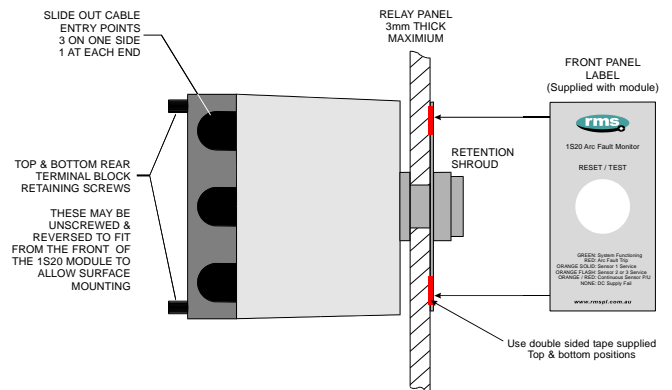

Figure 16: Panel mount version side view

Panel Mount Version

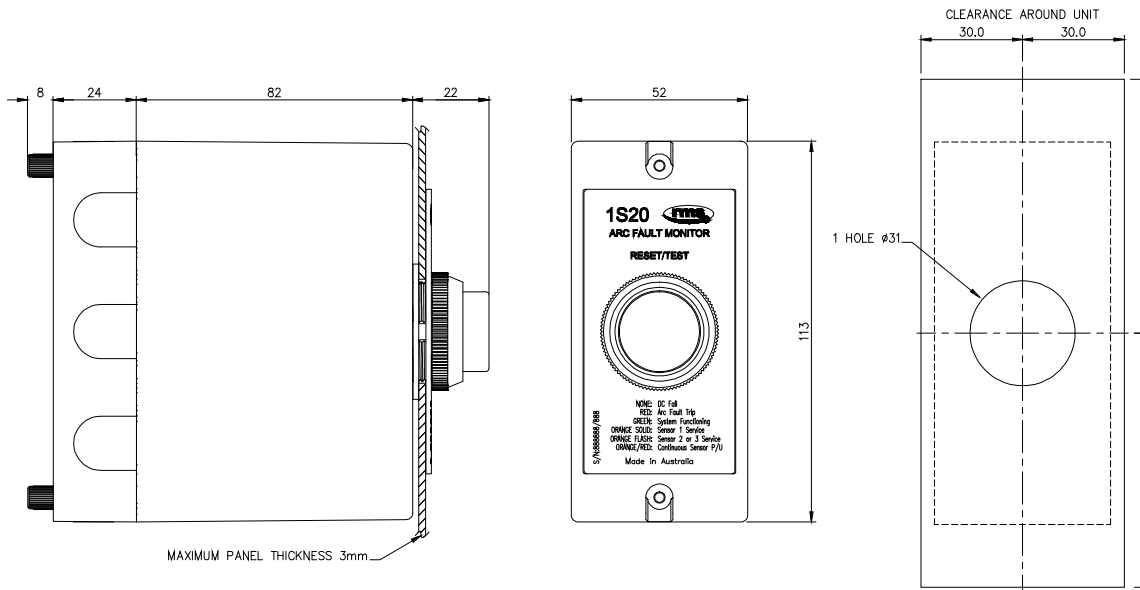

Figure 17: Panel mounting cut out detail

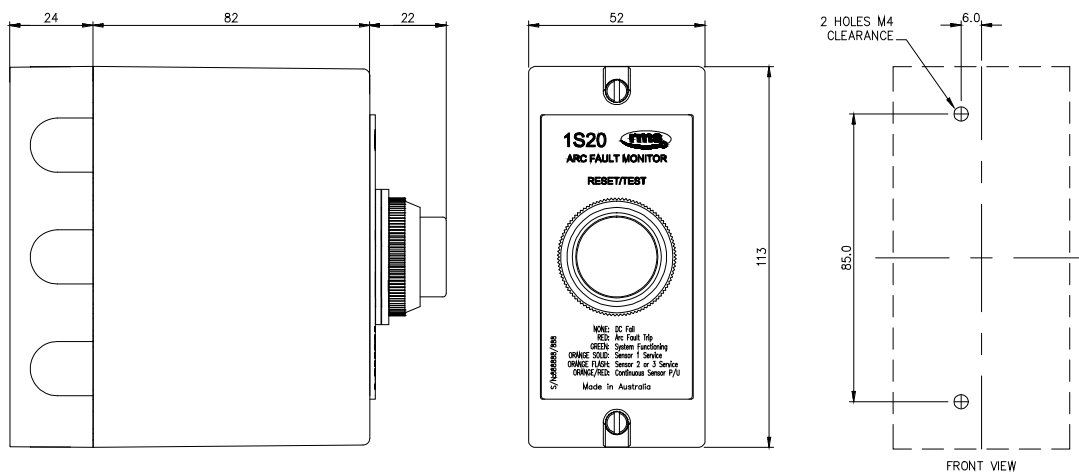

Figure 18: Surface mounting detail

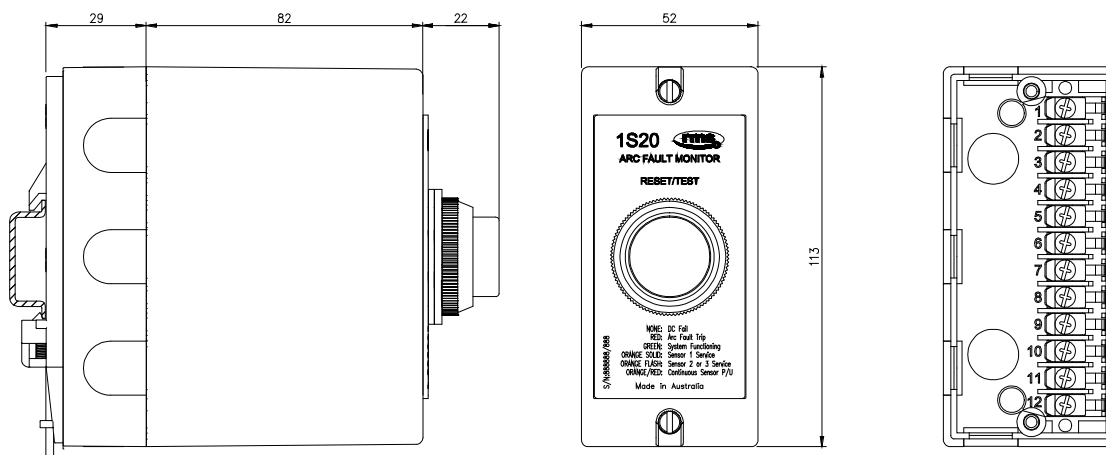

Figure 19: DIN rail mounting detail

Surface Mount Version

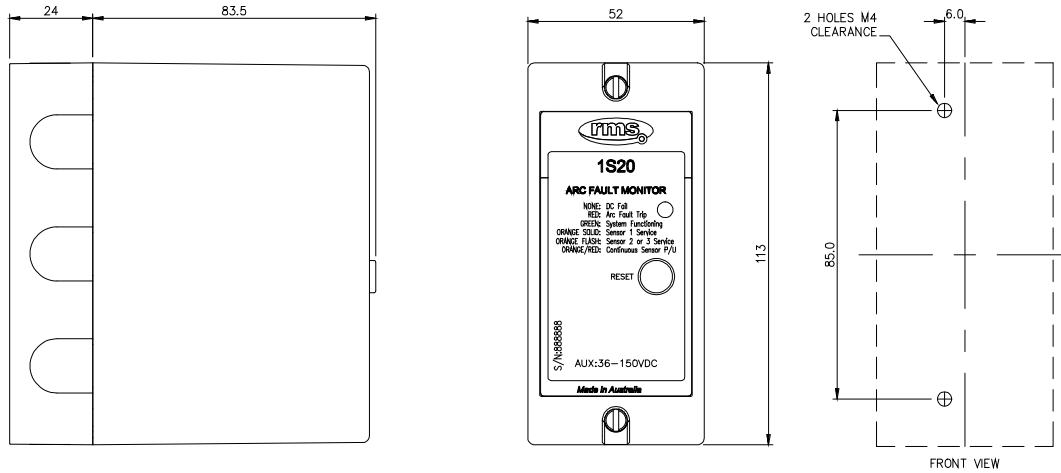

Figure 20: Surface mounting detail

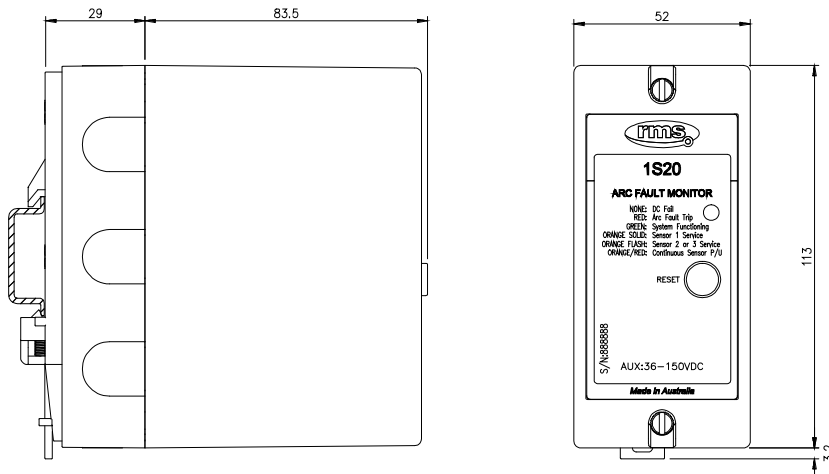

Figure 21: DIN rail mounting detail

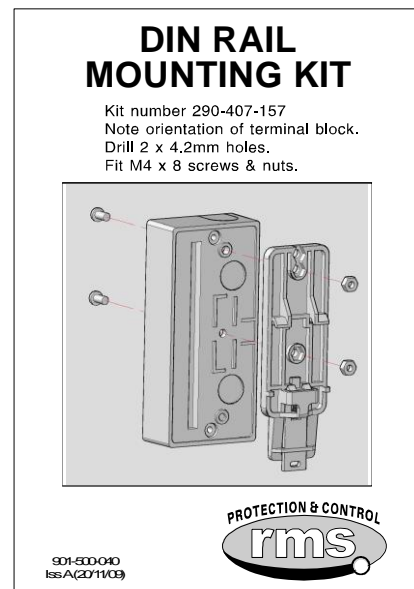
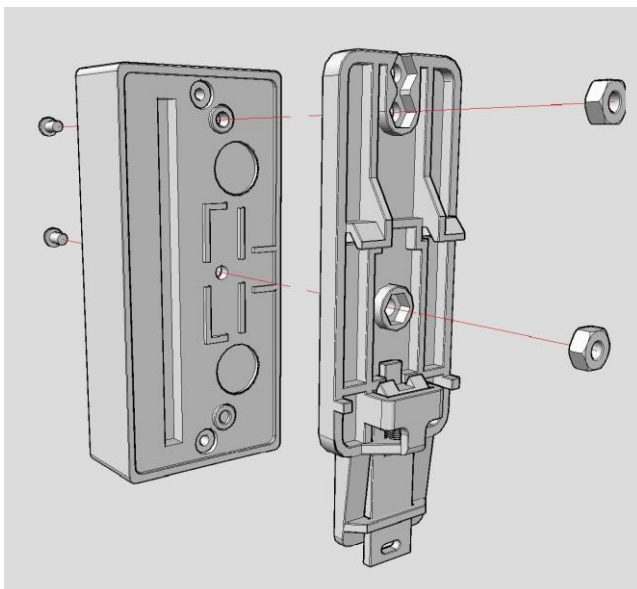

Figure 22: DIN rail clip fitting detail – Specify DIN Rail Mounting Kit P/N 290407157

1S20 Relay Order Codes

1S20 -		
Auxiliary Supply	F	19-85 V DC or 19-65V AC
	G	45-165 V DC or 38-150V AC
	H	125-250V DC or 95-240 V AC
Mounting	A	Panel mount or surface mount
	B	Surface mount only
	C	As per A with DIN rail kit supplied
	D	As per B with DIN rail kit supplied
Sensors	A	Two arc sensor inputs (Default)
	B	Three arc sensor inputs

Auxiliary Supply Order Code Change Guide

Old	Applied Auxiliary Voltage	New
1S20-Axx	24/32/48V DC	1S20-Fxx
1S20-Axx *	110V AC	1S20-Gxx #
1S20-Axx *	230/240/250V AC	1S20-Hxx #
1S20-Cxx	110/125V DC	1S20-Gxx
1S20-Dxx	220/240/250V DC	1S20-Hxx
1S20-Exx *	110V AC	1S20-Gxx #

* When used with AC/DC power supply adaptor
 # Direct connection to AC auxiliary supply

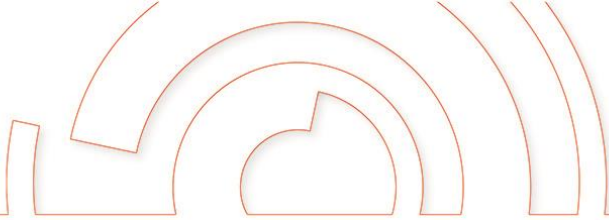

RMS Mors Smitt
19 Southern Court
Keysborough, VIC 3173, Australia
Tel: +61 (0)3 8544 1200
sales.rms@wabtec.com

Wabtec Netherlands B.V.
Darwinstraat 10
6718 XR Ede, Netherlands
Tel: +31 (0)88 600 4500
sales.msbv@wabtec.com



Visit www.morssmitt.com/rms for the latest product information.
Due to RMS continuous product improvement policy this information is subject to change without notice.

